

Yedi®
HOUSEWARE

YEDI TOTAL PACKAGE 6-IN-1 DIGITAL DELUXE GRILL



For more recipes and cooking videos go to:
www.yedihousewareappliances.com

Follow us on Instagram [@yedihouseware](https://www.instagram.com/yedihouseware)

CONTENTS

Important Safeguards	2
Product Contents.....	5
Product Parts.....	5
Before First Use.....	7
Control Panel	8
Operation	9
How To Make Waffles	10
How To Use a Flat Contact Grill.....	12
Using The Egg Rings.....	13
Cleaning & Care	14

Specifications:

- Model No. GV019
- Voltage 120V 60Hz
- Power 1600W (800W+800W)

IMPORTANT SAFEGUARDS

1. Use oven mitts when operating.
2. Do not allow this item to be used as a toy. Close attention is necessary when used by or near children. This appliance is not intended for use by children.
3. Do not use with a damaged cord or plug. Do not use if it has been dropped, damaged, left outdoors, or dropped in water. Contact manufacturer.
4. It is recommended to regularly inspect the appliance to avoid a hazard.
5. To protect against risk of electrical shock, do not immerse cord, plug or the appliance in water or other liquids. This may cause personal injury and/or damage to the product. See instructions for cleaning.
6. Fully unwind the power cord before use.
7. Never remove the plug from the socket by pulling the power cord. Always unplug from the plug gripping the area.
8. Do not let cord hang over the edge of the table, counter, or touch hot surfaces. Do not place on or near a gas or electric burner, or in a heated oven. Do not let the power cord become tangled.

IMPORTANT SAFEGUARDS

9. Unplug from power outlet when not in use and before cleaning. Allow unit to cool before removing parts and before cleaning the appliance.
10. Do not handle plug or appliance with wet hands.
11. Any maintenance other than cleaning should be performed at an authorized service center.
12. Use of attachments and or accessories not recommended or sold by the manufacturer may cause fire, electrical shock, injury or damage to the product.
13. The unit is not intended to be operated by means of an external timer or separate remote-control system.
14. Do not use outdoors.
15. This appliance is for household use only.
16. Do not use the appliance for anything other than its intended purpose. Misuse may cause injury.
17. To protect against fire, do not operate the unit in the presence of explosive and/or flammable fumes.
18. Extreme caution should be exercised when using or moving the appliance containing food or other hot liquids.
19. Do not move the appliance during cooking.
20. Use only a level, dry and heat-resistant surface. Do not place the Yedi Grill on the edge of a bench or table during operation. Ensure the surface is level, clean and free of water and other substances.

IMPORTANT SAFEGUARDS

21. Position the appliance well away from walls, curtains and other heat or steam sensitive materials. Minimum of 8 inches distance.
22. When using the appliance, provide adequate space above and on all sides for air circulation.
23. To eliminate a choking hazard for young children, remove and safely discard the protective cover that is fitted to the power plug on the appliance.
24. Remove any packaging material and promotional stickers before using the appliance for the first time.
25. Always ensure the appliance is properly assembled before use.
26. Never plug in or switch on the appliance without having the grill, griddle or waffle plates installed.
27. Unplug from outlet when not in use and before cleaning. Allow to cool before putting on or taking off parts, and before cleaning appliance.
28. Do not touch hot surfaces.

PRODUCT CONTENTS

1. Digital Grill
2. Reversible Grill/Griddle Plates
3. Waffle Plates
4. Tongs/Spatula
5. Egg Rings



PRODUCT PARTS

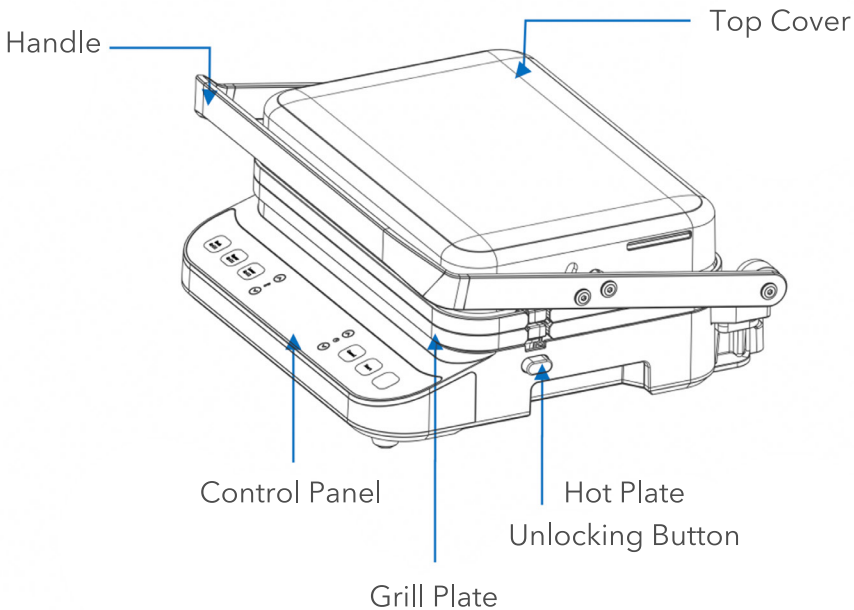

PRODUCT PARTS

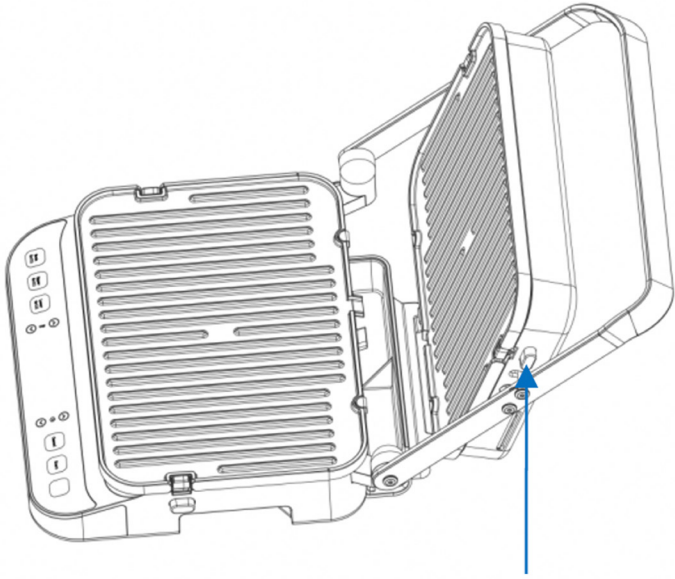

Upper Hot Plate
Unlocking Button

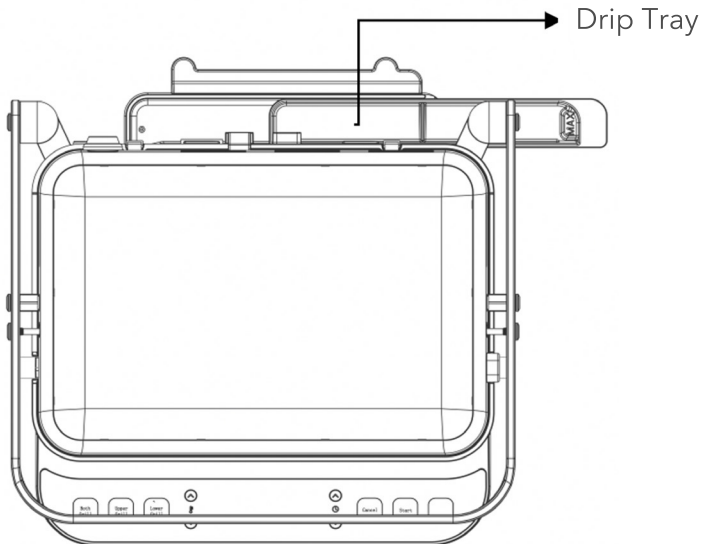

Drip Tray



Before First Use

1. Take the appliance out of the package and remove all the packaging material.
2. Remove the grill plates by pressing the unlocking button and pull them out. -Repeat for upper grill by pressing the upper plate unlocking button and pulling out the upper plate.





3. Before using any of the plates for the first time, clean them with warm water and a mild cleaning agent. Then thoroughly dry them with a soft cloth by hand.
4. Ensure that drip tray is inserted correctly at the back of appliance. It needs to be pushed all the way in so it is not sticking out from the back of the grill.



PRODUCT PARTS

Helpful Tips Before First Use:

- When unit in standby mode you can press “” and “” together for 3 seconds to change between °C and °F
- To reduce the preheating time, close the top and bottom plates during the preheating process. However, when using as a flat contact grill, for safety we recommend setting up the grill to be 180° flat, before pre-heating.
- Note that a short power supply cord is provided to reduce the hazards resulting from becoming entangled in or tripping over a longer cord.

How To Install Cooking Plates:

- To insert the grill plates or waffle plates align the bottom clips of the unit with the indentions of the plates and slide the plates into position properly, then push down. You should hear a click and they should now be secured into place.

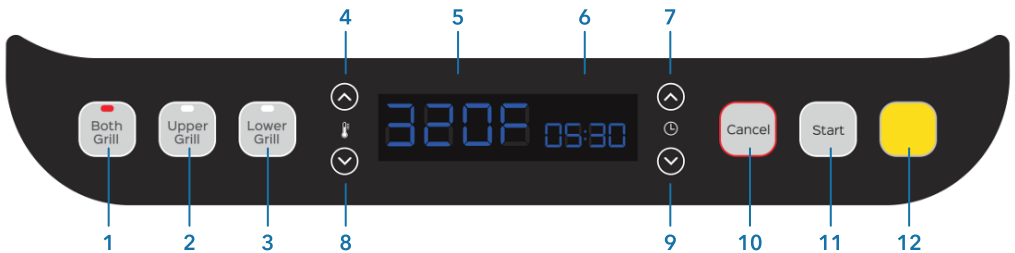

Note: The grill plates are reversible, use whichever side you desire

CONTROL PANEL



- | | |
|---------------------------------|-------------------------------|
| 1. Both plates heating together | 7. Increase cooking time |
| 2. Only upper plate heating | 8. Decrease cooking Temp |
| 3. Only lower plate heating | 9. Decrease cooking time |
| 4. Increase cooking Temp | 10. Cancel/Stop programing |
| 5. Temperature display | 11. Start cooking |
| 6. Time display | 12. Indication light of modes |

OPERATION

1. Initially when the unit is plugged in, it will beep and "OFF" will appear on the display screen.
2. Select your desired cooking function (Both Grill or Upper Grill or Lower Grill) by pressing the related button; Default time and temperature appear on display.
3. Adjust cooking time and temperature by pressing the corresponding buttons " " ""; unit will beep one time when button is pressed.
4. Once the desired temperature and cooking time have been set, press the "start" button to begin the preheating process. (If the "start" button is not pressed within 15 seconds the unit will enter standby mode, and "OFF" will appear on display).

During the preheating process your set temperature and "Pre" will appear on the display and the indication light will turn blue. On average, the unit will take about 5 minutes to preheat.

5. Once the pre-heating process is complete, the set temperature will appear on the display and the cooking time will start flashing. The unit will beep five times and the indication light will turn green.
6. Put the ingredients on the cooking plates and press the "Start" button. The indication light will turn yellow and the cook time will count down. (***DON'T FORGET TO PUSH START*** - if the "START" button is not pressed within 30 minutes, the unit will enter standby mode and "OFF" will appear on display).

Note: A modest amount of smoke might come out of the unit while cooking- this is normal.

7. When countdown is over, the unit will beep five times and "done" will appear on the display. The indication light will turn red.
8. Press the "Cancel" button at any time to enter into standby mode in order to change the cooking settings or turn off the appliance.

HOW TO MAKE WAFFLES

Recommended Ingredients:

- 1 cup of your favorite waffle mix
- 1 Egg
- 2 tsp of extra virgin olive oil
- $\frac{3}{4}$ cup of milk
(Non-dairy alternative: use $\frac{3}{4}$ cup of water as a substitute for milk)

Directions:

1. Insert both Waffle Plates into the unit and then close the grill.
2. Create waffle batter by mixing all the ingredients in a bowl until the big lumps are gone.
3. Choose "Both Grills" mode and set the temperature to 400°F and the time to 3:00 (3 minutes).
4. Press start and preheating will begin - preheat your grill closed. (Let your waffle batter rest during preheating. Preheating will take approximately 5 minutes).
5. Once the grill has finished pre-heating, open the grill.
6. Pour the waffle batter into the 2 back sections first until they are covered thoroughly.



HOW TO MAKE WAFFLES

Directions:

7. Then pour the waffle batter into the 2 front sections until they are covered thoroughly.
- 
8. Close the grill - make sure to press down firmly.
 9. Press the start button immediately. **DON'T FORGET TO PRESS THE START BUTTON**
 10. Once the timer is up, press cancel, open your Yedi grill and remove your waffles with the spatula/tongs and serve.
-

Waffle Tips:

- Be attentive, don't wonder off or you may burn your waffles.
- Before each use, make sure your waffle plates are clean of residue and previous burnt ingredients to avoid little black dots from forming on the surface of your waffles during the cooking process.
- When cooking multiple batches of waffles, we recommend preheating the grill before each batch to ensure optimum temperature and results.
- A modest amount of smoke might come out of the unit while cooking waffles, this is normal.

You can also watch how to make waffles using your Yedi Grill here:
<https://www.yedihousewareappliances.com/grill>

HOW TO USE AS A FLAT CONTACT GRILL

Step 1: Use the handle to open the grill and create a 90° angle between the top grill and bottom grill (L Shape).



Step 2: Push the outer part of the upper grill all the way forward and hold it in place while using your free hand to grip the handle and pull down the upper plate 180° flat.



Step 3: Set your desired cook time and temperature.

Step 4: Press start and preheating will begin.

Step 5: When preheating is complete place your ingredients on the plates.

Step 6: Press start

USING THE EGG RINGS

Step 1: Set your desired cook time and temperature

Step 2: Press start and preheating will begin.

Step 3: When preheating is complete place the egg racks onto the grill.

Step 4: Crack an egg into each egg ring and press start.



CLEANING AND CARE

Even if the appliance is not being used, disconnect the main plug from the socket before cleaning it and/or its individual parts.

1. Disconnect the appliance from the outlet and allow it to cool down for at least 30 minutes.
2. Using a soft sponge or non-abrasive cleaning brush remove the residue from the cooking plates.
3. Dispose of grease from drip tray once it has cooled down. The drip tray can easily be removed for cleaning by just sliding it out.
4. Press the unlock buttons to remove the plates from the grill. Be sure that the plates have cooled down completely before handling.
5. After removing the grill plates, you can clean them in warm soapy water or in the dishwasher.

User Maintenance:

1. Always be careful when handling the unit during cooking. Open and close the unit by using the handle only. Do not touch the top cover during or immediately after cooking, as top plate is hot during cooking.

We recommend always using oven mitts when handling the unit to avoid burns.

2. Never use metal utensils, as it will scratch the coating of plate.
3. Always let the unit to cool down for *30 minutes* before cleaning.

Error code:

1. E1: open circuit of upper thermostat, please contact manufacturer at info@yedihouseware.com
2. E2: short circuit of upper thermostat, please contact manufacturer at info@yedihouseware.com
3. E3: open circuit of lower thermostat, please contact manufacturer at info@yedihouseware.com
4. E4: short circuit of lower thermostat, please contact manufacturer at info@yedihouseware.com

Yedi[®]

H O U S E W A R E

